

CFB-CSL FLIP BOLT MORTICE LOCK - CONCEALED SHORT LEVER

1. CONCEALED SHORT LEVER COMPONENT PART LIST

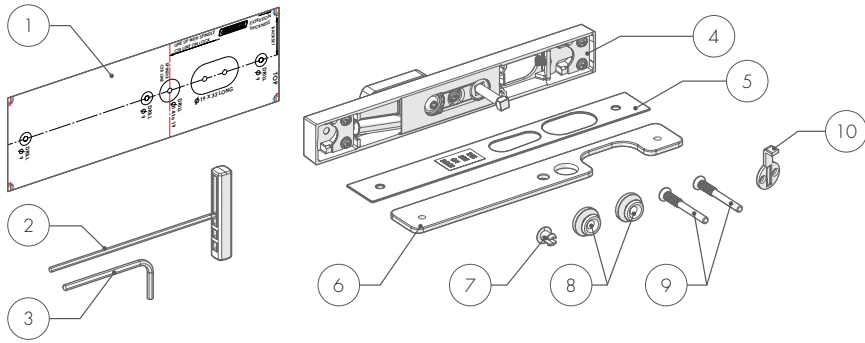

Item No.	Description	QTY
1	Drill Template	1
2	2.5mm T-Handle Allen Key	1
3	3mm Allen Key	1
4	Concealed Short Lever Faceplate	1
5	Slide Plate	1
6	Mounting Plate	1
7	Mounting Plate Clip	1
8	Mounting Boss	2
9	Mounting Screw	2
10	CSL Cam	1

REFERENCE DIMENSIONS FOR CONCEALED SHORT LEVER INSTALLATION

REFERENCE DIMENSIONS

Install Egress Handle using drilling template (next page)

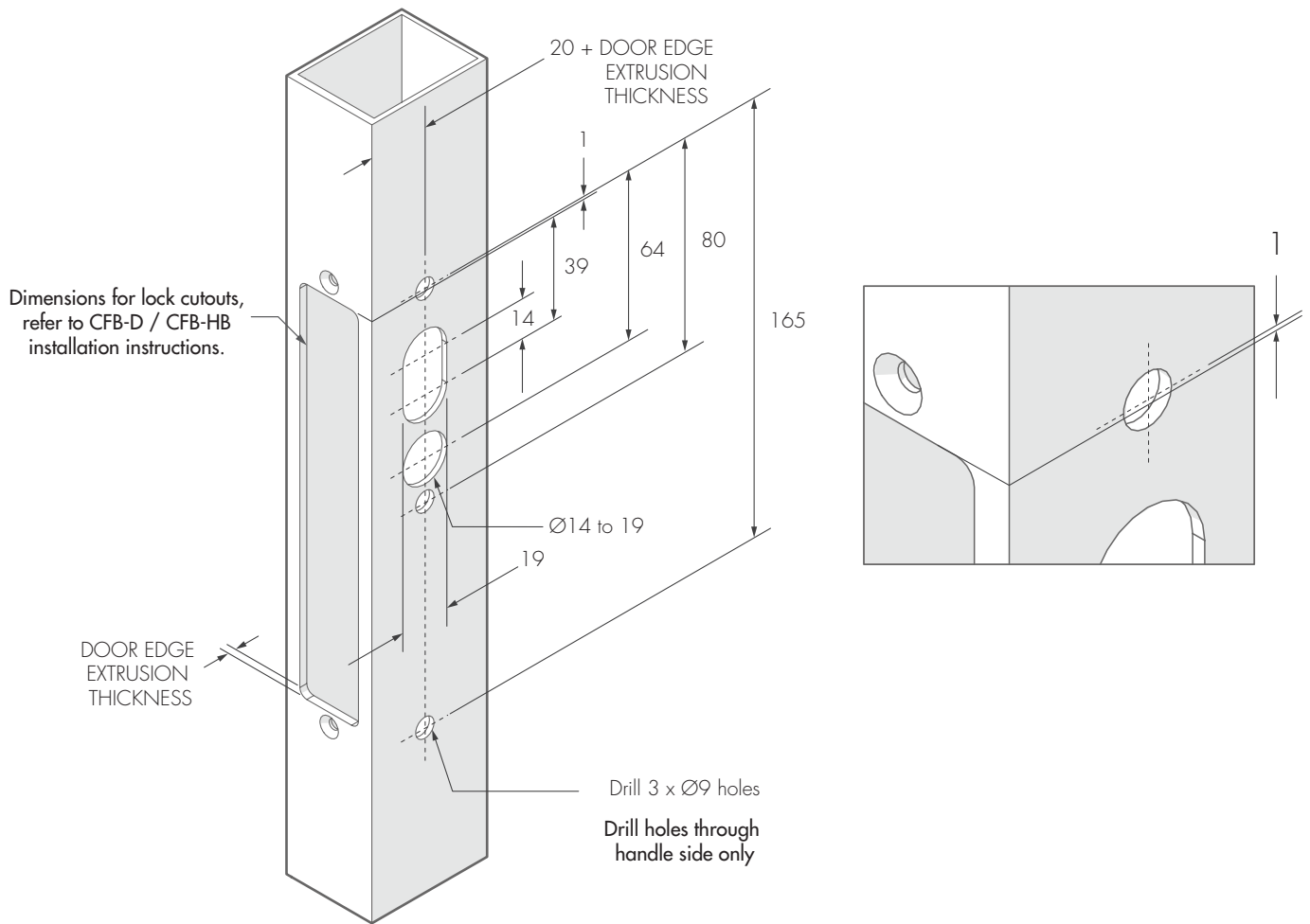

Special Notes:

For lock installation instructions, please refer to installation instructions provided with CFB-D / CFB-HB.
 For installation together with CLS-FAB - Flip Bolt Latching Strike, please refer to the installation instructions provided with CLS-FAB.
 For installation together with CFB-OCEP - Oval Cylinder Rectangular Escutcheon, please refer to the installation instructions provided with CFB-OCEP.

WARNING
 Please keep contents away from small children. Suffocation Hazard.
NOTE
 Please dispose of plastic bags and other packaging in a thoughtful manner



LOCK & KEY Phone: 1300 652 692 Web: www.locknkey.com.au
 Distributed in Australia by LOCK AND KEY a division on the DAVCOR GROUP PTY LTD ABN 95 003 542 598 This product has been manufactured in China to Lock and Key Company specifications

This product is guaranteed to be free from defects in materials and workmanship for a period of one (1) year from the date of original purchase. This warranty is for replacement of product only and Lock and Key Company does not accept responsibility for any direct or consequential damage caused by this product or its use. This warranty

Web: www.daveweb.com.au
 does not cover damage that results from faulty installation or usage, alteration or modification of the product or tarnishing of the finish including colour change due to weather, salt or chemical. Should this product not perform satisfactorily in its intended application, return it to place of purchase for replacement.



CFB-CSL FLIP BOLT MORTICE LOCK - CONCEALED SHORT LEVER

2. DRILLING TEMPLATE INSTRUCTIONS

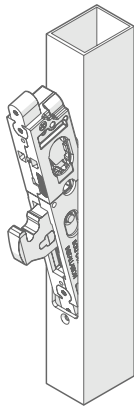

2A Insert lock into door cavity. ENSURE BOLT IS EXTENDED.

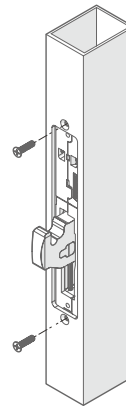

2B Secure with 2x M4x16mm CSK Screws (supplied with lock).

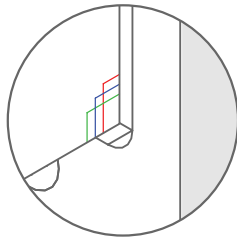
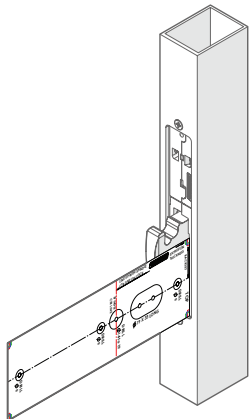

2C Insert drilling template into cutout and against lock face as shown.

Identify the colour that lines up (closest) with the door edge face.

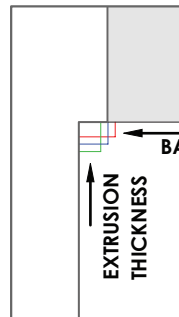

2D To determine the correct backset position, align the corresponding same coloured line at the top and bottom, as shown on the diagram. Ensure template is straight.

To determine the vertical position of the template, align the spindle ctr line with the spindle line on the lock

Mark drilling holes.

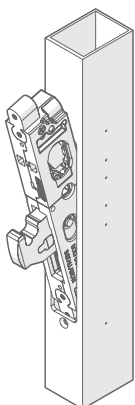
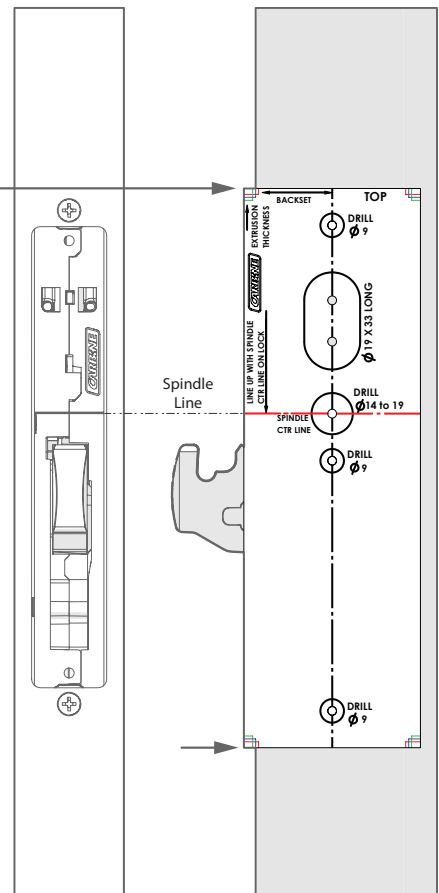

2E Remove the 2x M4x16mm CSK Screws and lock from the door.

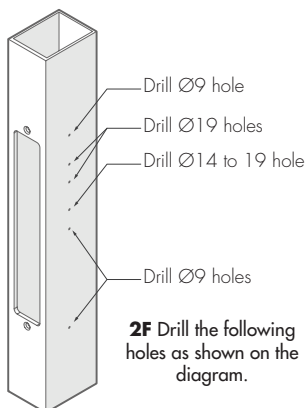

2F Drill the following holes as shown on the diagram.

Clean up opening for fitment of oval cylinder.

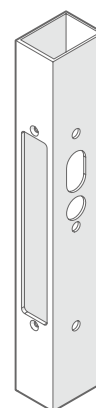

2G Preparation for installation of concealed short lever furniture and lock into metal door is now complete.

Continue with concealed short lever furniture installation instructions section 3.

CFB-CSL FLIP BOLT MORTICE LOCK - CONCEALED SHORT LEVER

3. INSTALLATION OF MAIN LOCK AND MOUNTING COMPONENTS

Ensure correct type of lock is used.
 CFB-D - Flip Bolt Mortice Lock - Internal Deadlocking
 or
 CFB-HB - Flip Bolt Mortice Lock - Hold Back

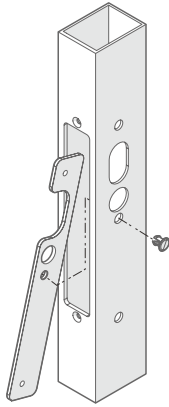

3A Insert mounting plate into door cavity, do not drop inside door. Firmly press mounting plate clip through the door extrusion into the mounting plate.

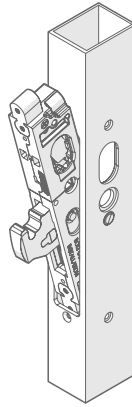

3B Insert lock into door cavity. ENSURE BOLT IS EXTENDED

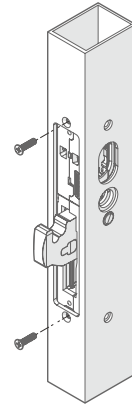

3C Secure with 2x M4x16mm CSK Screws (supplied with lock).

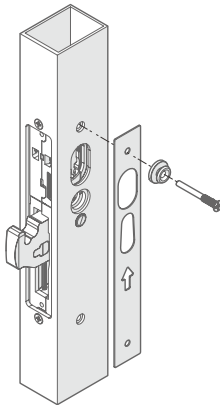

3D Insert 1x mounting screw through 1x mounting boss and slide plate into the top mounting plate hole and into lock. Fasten to retain, do not tighten.

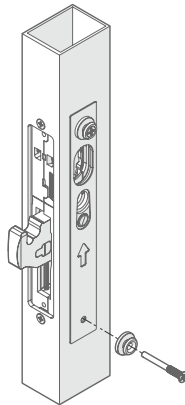

3E Insert 1x mounting screw through 1x mounting boss and slide plate into the bottom mounting plate hole and into lock. Fasten to retain, do not tighten.

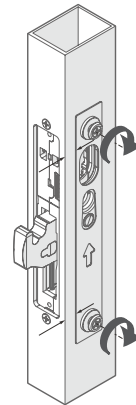

3F Align the slide plate to be even and parallel with the door edge and tighten the mounting screws.

4. LEFT-HAND CONFIGURATION (FACTORY SUPPLIED)

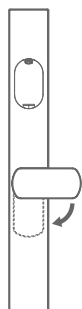

Left-hand Configuration

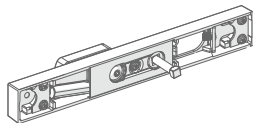

4A Factory supplied. Configured as left-hand door furniture.

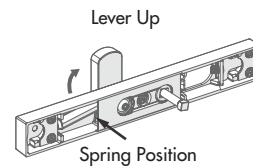

4B Rotate the short lever into the up position. The spring should be in the upper position as shown on the diagram.

If no change of handing is required, skip to step 6A for installation onto door.

If change of handing is required, continue to step 5A.

CFB-CSL FLIP BOLT MORTICE LOCK - CONCEALED SHORT LEVER

5. CHANGE OF HANDING TO RIGHT-HAND CONFIGURATION

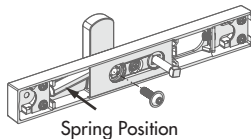
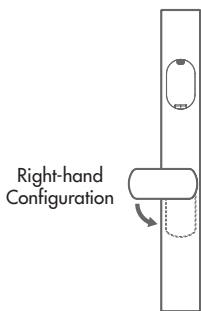

5A Remove central handle mounting screw using supplied 3mm allen key.

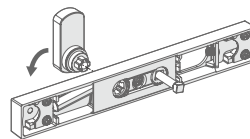

5B Remove short lever together with nylon bearing washer and hub. Ensure parts are kept assembled together.

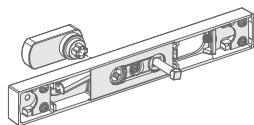

5C Rotate the short lever counter-clockwise 90° as shown on the diagram.

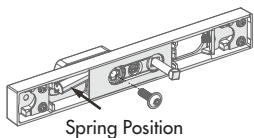

5D Whilst spring is as shown, replace short lever back into door furniture and securely re-fasten the central handle mounting screw.

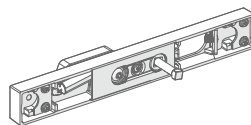

5E Test the short lever rotation to ensure the position is in right-hand configuration.

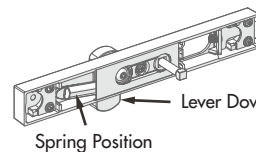

5F Rotate the short lever counter-clockwise 90° into the downward position as shown on the diagram.

6. INSTALLATION OF CONCEALED SHORT LEVER

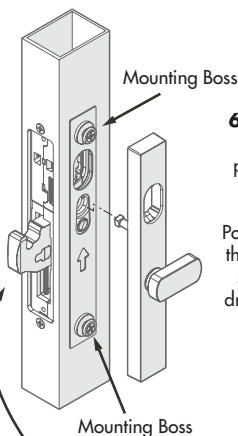

6A Ensure short lever is in the horizontal position and the lock bolt is extended.

Position the faceplate to the door and insert the spindle into the lock drive and the faceplate over the mounting bosses.

Ensure lock bolt is extended

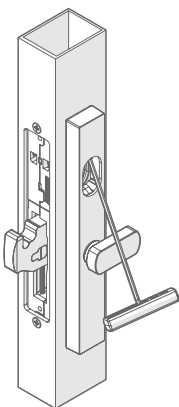

6B Whilst keeping the furniture flush with the slide plate, insert the supplied 2.5mm T-handle allen key into the grub screw inside the top of the cylinder hole.

Rotate the grub screw clockwise until tight, sliding the faceplate downwards into its fitted position.

Remove allen key afterwards.

Test lever operation.

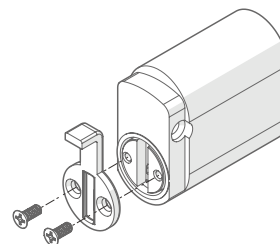

6C Attach CSL cam to oval key cylinder.

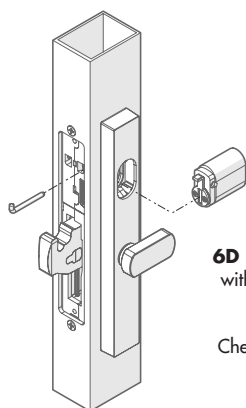

6D Insert oval key cylinder with CSL cam and secure with retainer pin.

Check retainer pin is flush with lock body.

Insert oval key cylinder and retainer pin if required.

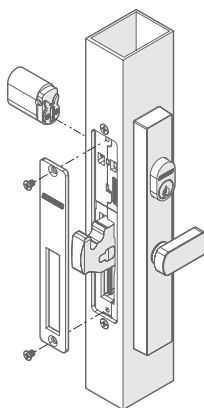

6E Insert oval key cylinder and secure retainer pin if required.**

Attach cover plate to lock and secure with 2x M4x6mm CSK Screws.

**With rabbit ear / R cam fitted on the oval cylinder.

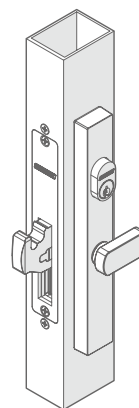
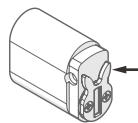

6F Installation is now complete.

Special Notes:

For lock installation instructions, please refer to installation instructions provided with CFB-D / CFB-HB.

For installation together with CLS-FAB - Flip Bolt Latching Strike, please refer to the installation instructions provided with CLS-FAB.

For installation together with CFB-OCEP - Oval Cylinder Rectangular Escutcheon, please refer to the installation instructions provided with CFB-OCEP.

WARNING
Please keep contents away from small children. Suffocation Hazard.

NOTE
Please dispose of plastic bags and other packaging in a thoughtful manner



LOCK & KEY Phone: 1300 652 692 Web: www.locknkey.com.au
Distributed in Australia by LOCK AND KEY a division of the DAVCOR GROUP PTY LTD ABN 95 003 562 598. This product has been manufactured in China to Lock and Key Company specifications

This product is guaranteed to be free from defects in materials and workmanship for a period of one (1) year from the date of original purchase. This warranty is for replacement of product only and Lock and Key Company does not accept responsibility for any direct or consequential damage caused by this product or its use. This warranty

does not cover damage that results from faulty installation or usage, alteration or modification of the product or tarnishing of the finish including colour change due to weather, salt or chemical. Should this product not perform satisfactorily in its intended application, return it to place of purchase for replacement.